

SpinLink34 – Robot Interface Board, TUM 2012

top down view, 65x40mm

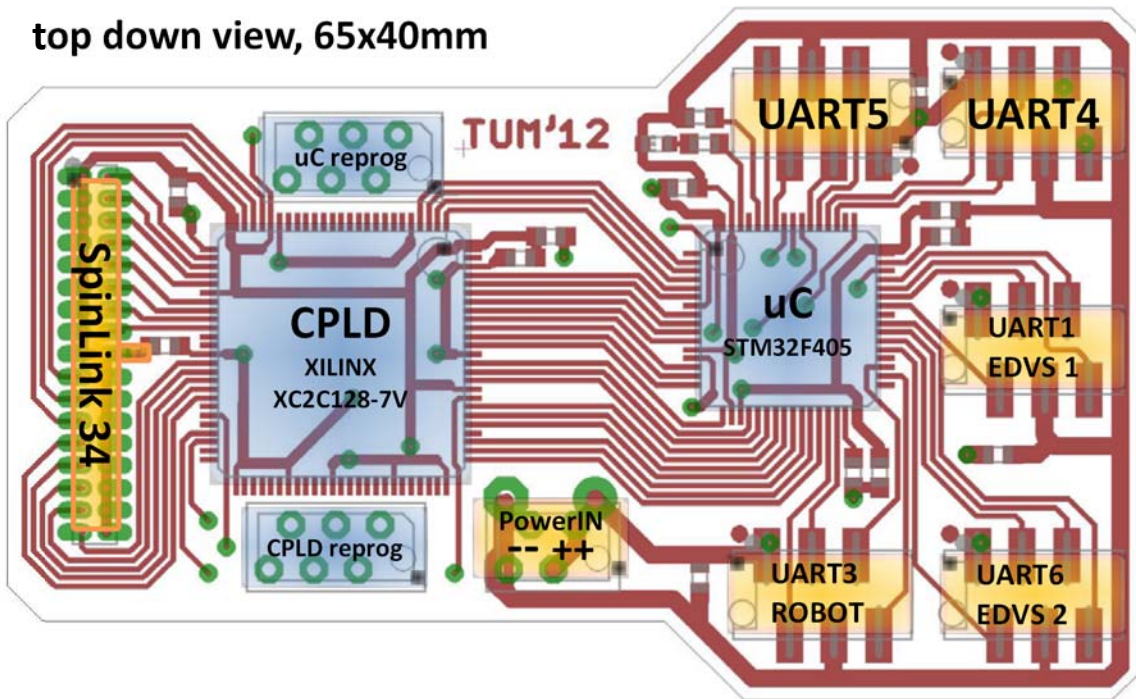

Current setup (12.11.2012)

- UART 1: eDVS @ 4mbps
- UART 6: Robot @ 4mbps
- UART 3: PC debug @ 2mbps
- UART 4: spare, not yet implemented
- UART 5: spare, not yet implemented